

BUSH HOG®

1747 FRONT END LOADER

Published 05/11

MATERIAL HANDLING PARTS MANUAL

PARTS MANUAL SECTION 1-28



An Operator's Manual was shipped with the equipment . The Operator's Manual is an integral part of the safe operation of this machine and must be maintained with the unit at all times. **READ, UNDERSTAND, and FOLLOW** the Safety and Operation Instructions contained in this manual before operating the equipment. If the Operator's Manual is not with the equipment, contact your dealer or Bush Hog to obtain a Free copy before operating the equipment.

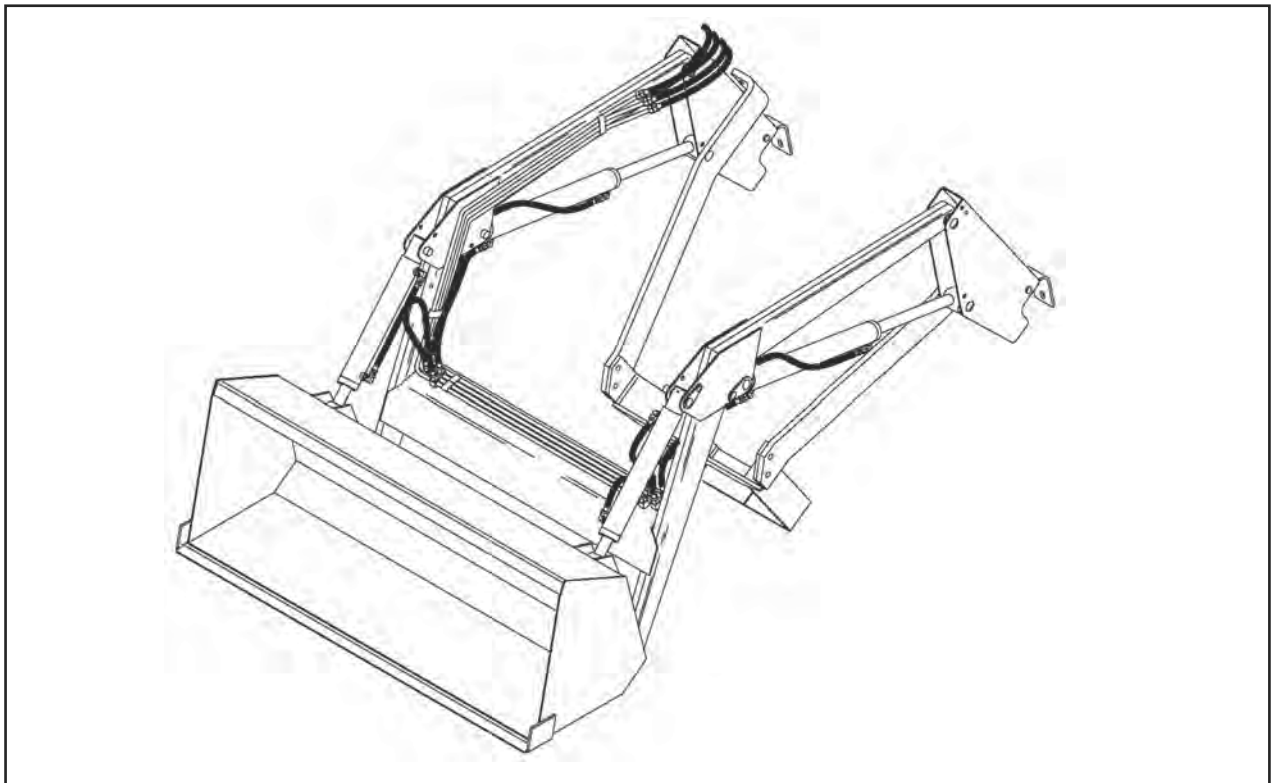

BUSH HOG®

2501 Griffin Ave.
Selma, AL 36703
Parts Ordering 1-800-304-2836
www.bushhog.com

ATENCIÓN!

LEA EL INSTRUCTIVO

Si No Lee Ingles, Pida Ayuda a Alguien
Que Si Lo Lea Para Que le Traduzca las
Medidas de Seguridad.



A MEMBER OF THE
ALAMO GROUP
ALWAYS ON THE CUTTING EDGE®

© 2011 Alamo Group Inc.

PARTS ORDERING GUIDE

The following instructions are offered to help eliminate needless delay and error in processing purchase orders for the equipment in this section.

1. The Parts Section is prepared in logical sequence and grouping of parts that belong to the basic machine featured in this manual. Part Numbers and Descriptions are given to help locate the parts and quantities required.
2. The Purchase Order must include the name and address of the person or organization ordering the parts, who should be charged, and if possible, the serial number of the machine for which the parts are ordered.
3. The Purchase Order must clearly list the quantity of each part, the complete and correct part number (be sure to include all periods), and the basic name of the part.
4. The Manufacturer reserves the right to substitute parts where applicable.
5. Some parts are unlisted items which are special production items not normally stocked and are subject to special handling. Request a quotation for such parts before sending a Purchase Order.
6. The Manufacturer reserves the right to change prices without prior notice.



For maximum safety and to guarantee optimum product reliability, always use genuine BUSH HOG Parts. The use of inferior replacement parts may cause premature or catastrophic failure which could result in serious injury or death. Direct any questions regarding parts to:

BUSH HOG
2501 Griffin Ave.
Selma, AL 36703
www.bushhog.com
Contact Us
800-304-2836



BUSH HOG®

To the Owner/Operator/Dealer

All implements with moving parts are potentially hazardous. There is no substitute for a cautious, safe-minded operator who recognizes the potential hazards and follows reasonable safety practices. The manufacturer has designed this implement to be used with all its safety equipment properly attached to minimize the chance of accidents.

BEFORE YOU START!! Read the safety messages on the implement and shown in your manual. Observe the rules of safety and common sense!

WARNING

TO AVOID SERIOUS INJURY OR DEATH:

1. READ AND UNDERSTAND OPERATOR'S MANUAL.
2. TRACTOR MUST BE EQUIPPED WITH ROLL-OVER PROTECTION (ROPS) AND SWAY CHAINS.
3. ALWAYS WEAR SAFETY GLASSES, SAFETY SHOES AND SEAT BELT FASTENED TIGHTLY.
4. STOP TRACTOR, LOCK BRAKES, AND BLOCK UP OR SUPPORT IMPLEMENT SECURELY BEFORE WORKING UNDER RAISED COMPONENTS.
5. ALLOW NO RIDERS AT ANY TIME ON TRACTOR OR IMPLEMENT. FALLING OFF CAN KILL.
6. KEEP BYSTANDERS CLEAR OF MOVING PARTS AND WORKING AREA. KEEP CHILDREN AWAY!
7. DO NOT LIFT, LOWER, OR OPERATE UNLESS EVERYONE IS CLEAR OF IMPLEMENT.
8. USE INCREASED CAUTION ON SLOPES & NEAR BANKS AND DITCHES TO PREVENT OVERTURN.
9. LOCK LIFT LEVER UP FOR TRANSPORT. HAVE SMV SIGN VISIBLE. FOLLOW LOCAL LAWS.
10. USE PARKING STAND OR BLOCK UP WHEN UNHITCHING FROM TRACTOR.

998200

WARRANTY INFORMATION:

Read and understand the complete Warranty Statement found in this Manual. It is the dealer's responsibility to register this product for warranty coverage with Bush Hog and to give the customer a copy of the warranty registration document.

LIMITED WARRANTY

Bush Hog warrants to the original purchaser of any new Bush Hog equipment, purchased from an authorized Bush Hog dealer, that the equipment be free from defects in material and workmanship for a period of one (1) year for non-commercial, state and municipalities' use and ninety (90) days for commercial use from date of retail sale. The obligation of Bush Hog to the purchaser under this warranty is limited to the repair or replacement of defective parts.

Replacement or repair parts installed in the equipment covered by this limited warranty are warranted for ninety (90) days from the date of purchase of such part or to the expiration of the applicable new equipment warranty period, whichever occurs later. Warranted parts shall be provided at no cost to the user at an authorized Bush Hog dealer during regular working hours. Bush Hog reserves the right to inspect any equipment or parts which are claimed to have been defective in material or workmanship.

DISCLAIMER OF IMPLIED WARRANTIES & CONSEQUENTIAL DAMAGES

Bush Hog's obligation under this limited warranty, to the extent allowed by law, is in lieu of all warranties, implied or expressed, **INCLUDING IMPLIED WARRANTIES OF MERCHANTABILITY AND FITNESS FOR A PARTICULAR PURPOSE** and any liability for incidental and consequential damages with respect to the sale or use of the items warranted. Such incidental and consequential damages shall include but not be limited to: transportation charges other than normal freight charges; cost of installation other than cost approved by Bush Hog; duty; taxes; charges for normal service or adjustment; loss of crops or any other loss of income; rental of substitute equipment, expenses due to loss, damage, detention or delay in the delivery of equipment or parts resulting from acts beyond the control of Bush Hog.

THIS LIMITED WARRANTY SHALL NOT APPLY:

1. To vendor items which carry their own warranties, such as engines, tires, and tubes.
2. If the unit has been subjected to misapplication, abuse, misuse, negligence, fire or other accident.
3. If parts not made or supplied by Bush Hog have been used in connection with the unit, if, in the sole judgement of Bush Hog such use affects its performance, stability or reliability.
4. If the unit has been altered or repaired outside of an authorized Bush Hog dealership in a manner which, in the sole judgement of Bush Hog, affects its performance, stability or reliability.
5. To normal maintenance service and normal replacement items such as gearbox lubricant, hydraulic fluid, worn blades, or to normal deterioration of such things as belts and exterior finish due to use or exposure.
6. To expendable or wear items such as teeth, chains, sprockets, belts, springs and any other items that in the company's sole judgement is a wear item.

NO EMPLOYEE OR REPRESENTATIVE OF BUSH HOG IS AUTHORIZED TO CHANGE THIS LIMITED WARRANTY IN ANY WAY OR GRANT ANY OTHER WARRANTY UNLESS SUCH CHANGE IS MADE IN WRITING AND SIGNED BY BUSH HOG'S SERVICE MANAGER, 2501 GRIFFIN AVE., SELMA, ALABAMA 36703.

Record the model number, serial number and date purchased. This information will be helpful to your dealer if parts or service are required.

MODEL NUMBER _____

SERIAL NUMBER _____

DATE OF RETAIL SALE _____

MAKE CERTAIN THE WARRANTY
HAS BEEN FILED WITH BUSH HOG
SELMA, ALABAMA

TABLE OF CONTENT

1747 FRONT END LOADER

ITEM	PAGE
 FRAMES	
Mainframe and Subframe	1-28A-1
 MOUNTING KITS	
Mounting Kit 2-6772 Kubota Models - BX 1800, BX 1830, BX 2200, BX 2300 FWA, COMPATABLE WITH RCK54-22BX AND RCK60B-22BX MID MOUNT MOWERS	1-28B-1
Mounting Kit 2-7325 Kubota Models - BX 1500 FWA, COMPATABLE WITH RCK54-15BX Mid Mount Mowers	1-28B-2
Mounting Kit 2-7407 Massey Ferguson Models - GC2300 FWA	1-28B-3
Mounting Kit 2-7442 Case IH Models DX18E, DX22E, DX24E AND DX25E FWA New Holland Models - TZ18DA, TZ22DA, TZ24DA, TZ25DA FWA, T1010, Boomer1020 FWA	1-28B-4
 ATTACHMENTS	
Bucket	1-28C-1
 HYDRAULICS	
Hydraulic System (Basic Loader)	1-28D-1
Hydraulic Valve (Dukes)	1-28D-2
Hydraulic Cylinder (Lift)	1-28D-3
Hydraulic Cylinder (Bucket)	1-28D-4
<i>Control Valve And Plumbing Kit 2-7553</i> Kubota Models - BX1500, BX1800, Bx1830, Bx2200, Bx2230	1-28E-1, 1-28E-2
<i>Control Valve And Plumbing Kit 2-7408</i> Massey Ferguson Models - GC2300	1-28E-3, 1-28E-4, 1-28E-5
<i>Control Valve And Plumbing Kit 2-7443</i> Case IH Models DX18E, DX22E, DX24E AND DX25E FWA New Holland Models - TZ18DA, TZ22DA, TZ24DA, TZ25DA FWA, T1010, Boomer1020 FWA	1-28E-6, 1-28E-7
 DECALS	
Decals (Placement)	1-28F-1
Decals (Pictorials)	1-28F-2

NOTES:

1747 MAINFRAME AND SUBFRAME

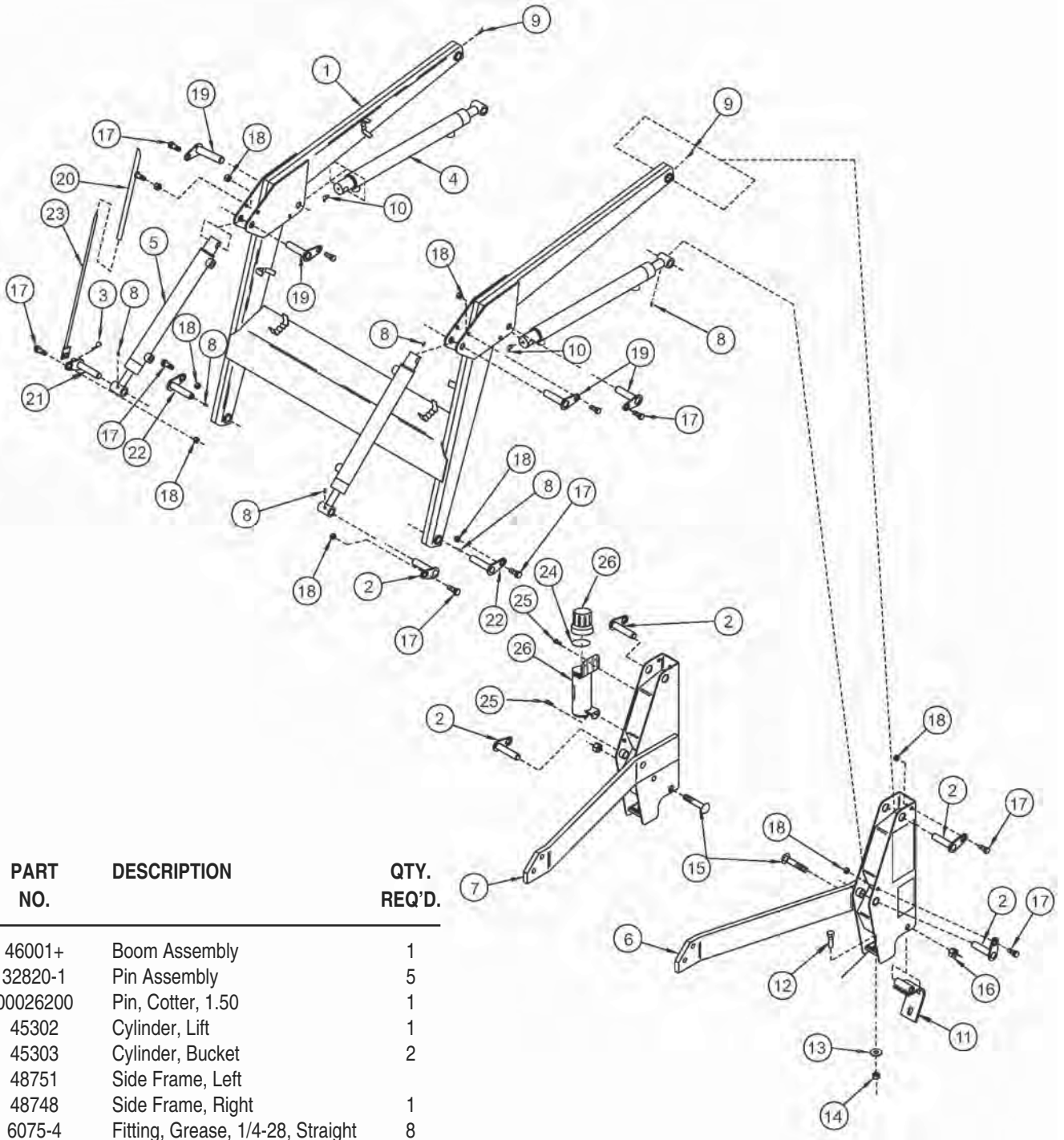

REF. NO.	PART NO.	DESCRIPTION	QTY. REQ'D.
1	46001+	Boom Assembly	1
2	32820-1	Pin Assembly	5
3	00026200	Pin, Cotter, 1.50	1
4	45302	Cylinder, Lift	1
5	45303	Cylinder, Bucket	2
6	48751	Side Frame, Left	
7	48748	Side Frame, Right	1
8	6075-4	Fitting, Grease, 1/4-28, Straight	8
9	6075-6	Fitting, Grease, 1/4-28, 45°	2
10	6075-7	Fitting, Grease, 1/4-28, 90°	2
11	45587	Hinge Assembly	2
12	-----	Screw, Cap, 1/2 X 1-3/4	2
13	00002700	Washer, Flat, 1/2	2
14	-----	Nut, Lock, 1/2-13	2
15	-----	Carriage Bolt, 5/8-11 X 3-1/2	2
16	-----	Nut, Lock, 5/8-11	2
17	31353	Bolt, Shoulder, 3/8-16 X 1	12
18	-----	Nut, Lock, 3/8-16	12
19	32820-2	Pin Assembly	4

REF. NO.	PART NO.	DESCRIPTION	QTY. REQ'D.
20	25210	Guide Tube	1
21	32823+	Pin Assembly	1
22	36118	Pin Assembly	2
23	32825+	Rod Assembly	1
24	00776964	Seal, Manual Canister	1
25	-----	Screw, Self Tapping, .25 X .75	2
26	00776031	Canister With Cap, Includes Item 31	1

MOUNTING KIT 2-6772

Kubota Models - BX 1800, BX 1830, BX 2200, BX 2300 FWA, COMPATABLE WITH RCK54-22BX AND RCK60B-22BX MID MOUNT MOWERS

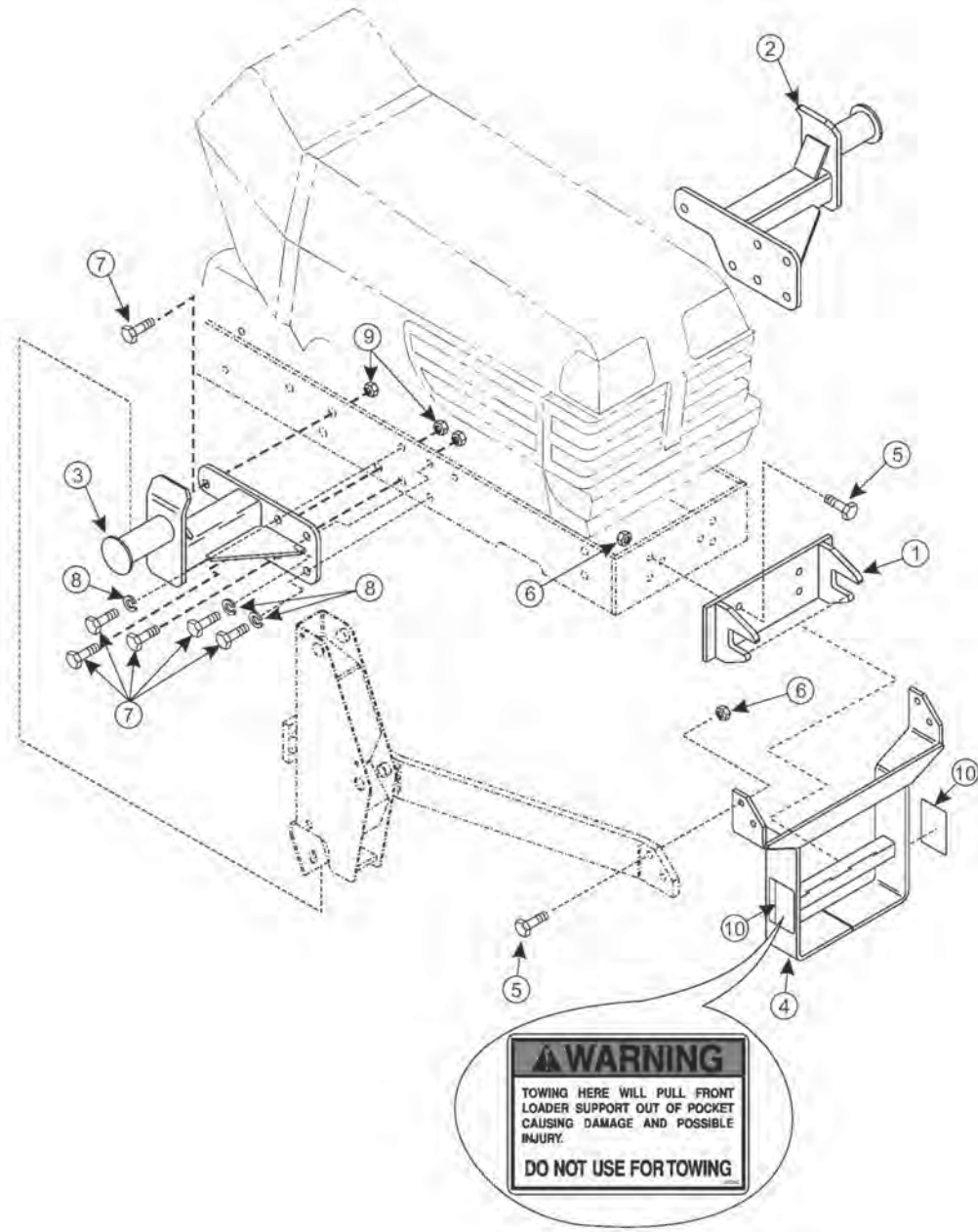

REF. NO.	PART NO.	DESCRIPTION	QTY. REQ'D.
1	48739	Front Mounting Bracket	1
2	48736-1	Mounting Bracket, Left	1
3	48736-2	Mounting Bracket, Right	1
4	49197	Yoke Assy. w/Safety Decal	1
5	-----	Capscrew 1/2"-13 x 1-1/2"	8
6	-----	Locknut 1/2" -13	8
7	-----	Capscrew 9/16"-18 x 1-1/2"	12
8	-----	Lockwasher 9/16"	6
9	-----	Locknut 9/16" -18	6
10	39240	Warning Decal	2

MOUNTING KIT 2-7325

Kubota Models - BX 1500FWA, COMPATABLE WITH RCK54-15BX MID MOUNT MOWERS

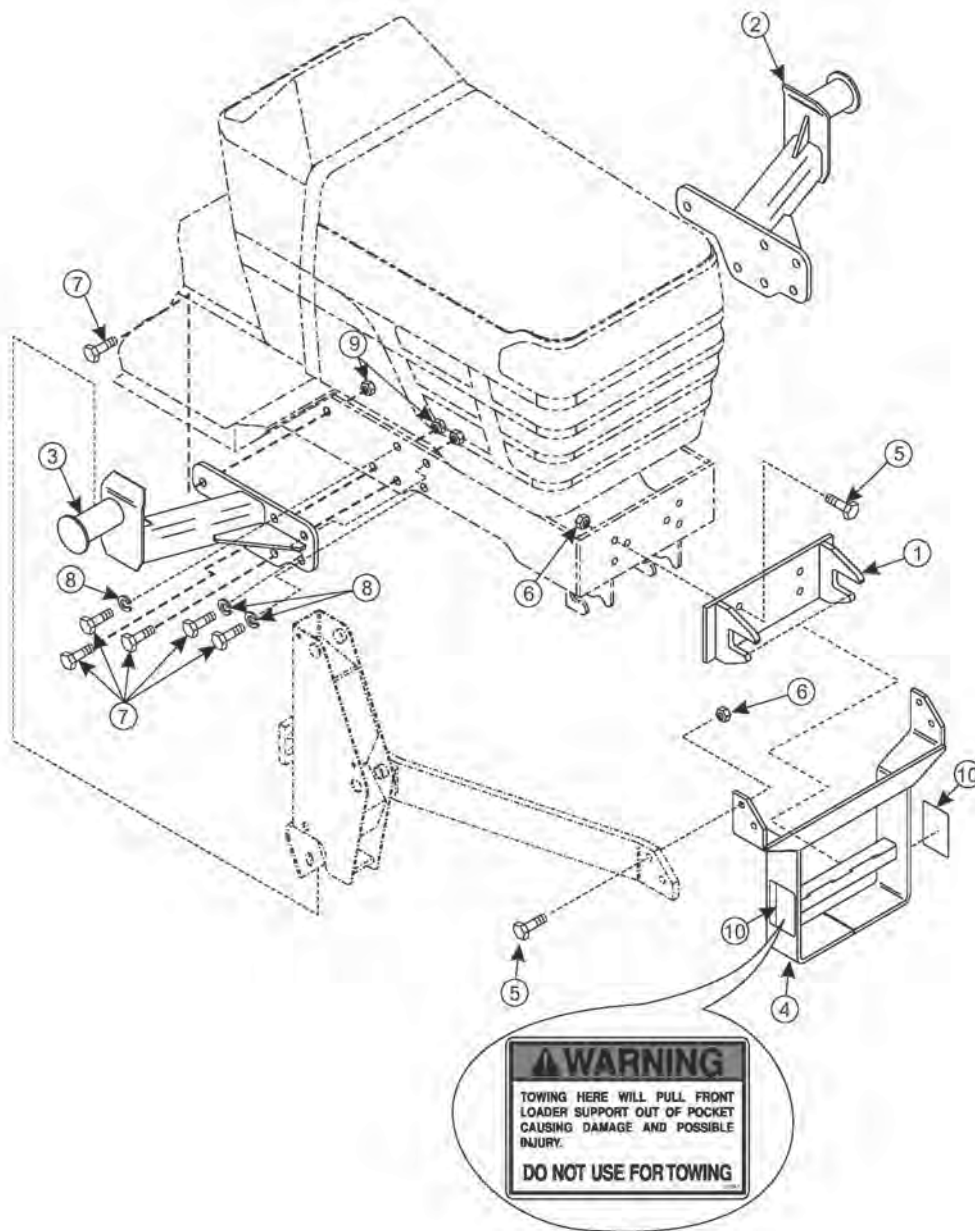

REF. NO.	PART NO.	DESCRIPTION	QTY. REQ'D.
1	51601	Front Mounting Bracket	1
2	51595-1	Mounting Bracket, Left	1
3	51595-2	Mounting Bracket, Right	1
4	49197	Yoke Assy. w/Safety Decal	1
5	-----	Capscrew 1/2"-13 x 1-1/2"	8
6	-----	Locknut 1/2" -13	8
7	-----	Capscrew 9/16"-18 x 1-1/2"	12
8	-----	Lockwasher 9/16"	6
9	-----	Locknut 9/16" -18	6
10	39240	Warning Decal	2

MOUNTING KIT 2-7407

Massey Ferguson Models - GC2300 FWA

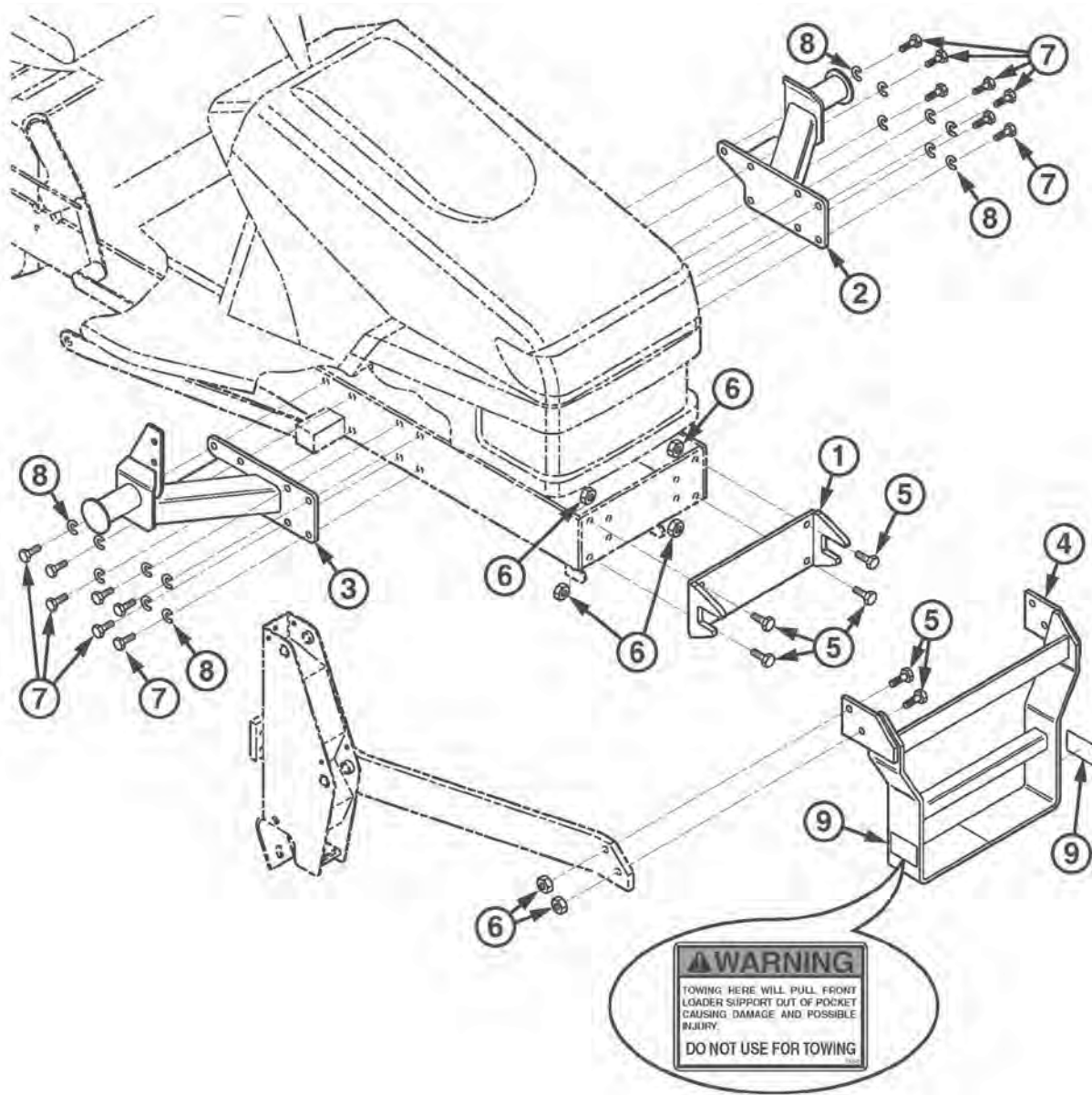

REF. NO.	PART NO.	DESCRIPTION	QTY. REQ'D.
1	52173	Front Mounting Bracket	1
2	52180	Mounting Bracket, Left	1
3	52182	Mounting Bracket, Right	1
4	52501	Yoke Assy. w/Safety Decal	1
5	-----	Capscrew 1/2"-13 x 1-1/2"	8
6	-----	Locknut 1/2" -13	8
7	-----	Capscrew M12-1.75 x 40	12
8	-----	Lockwasher 1/2"	6
9	39240	Warning Decal	2

MOUNTING KIT 2-7442

Case IH Models DX18E, DX22E, DX24E AND DX25E FWA
 NEW HOLLAND MODELS - TZ18DA, TZ22DA, TZ24DA, TZ25DA FWA, T1010,
 BOOMER1020 FWA

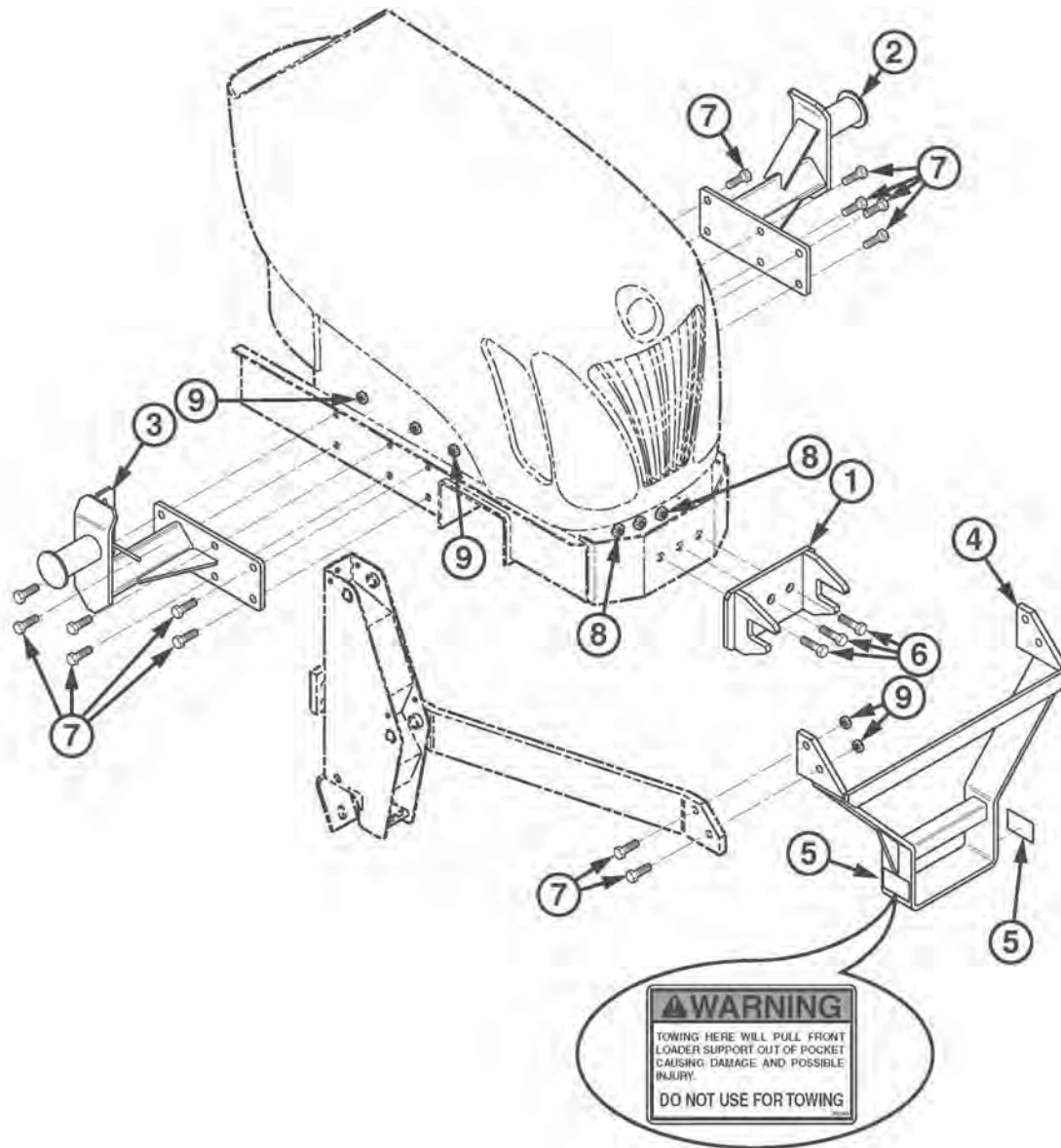

REF. NO.	PART NO.	DESCRIPTION	QTY. REQ'D.
1	52507	Front Mounting Bracket	1
2	52518	Mounting Bracket, Left	1
3	52519	Mounting Bracket, Right	1
4	52513	Yoke Assy. w/Safety Decal	1
5	39240	Warning Decal	2
6	-----	Capscrew 5/8"-11 X 1-1/2"	3
7	-----	Capscrew 1/2"-13 x 1-1/2"	16
8	-----	Locknut 5/8"-11	3
9	-----	Locknut 1/2"-13	16

BUCKET ASSEMBLY

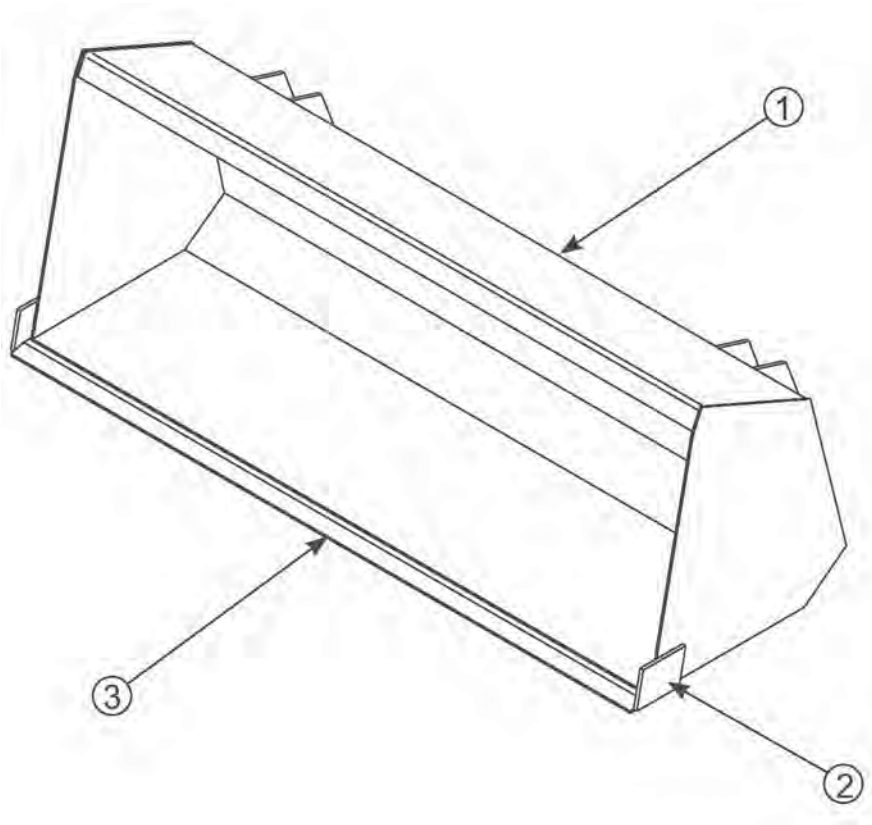

REF. NO.	PART NO.	DESCRIPTION	QTY. REQ'D.
1	36070	Bucket Assembly 48"	1
2	36068	Side Cutting Edge	2
3	22541-2	Bottom Cutting Edge	1

HYDRAULIC SYSTEM

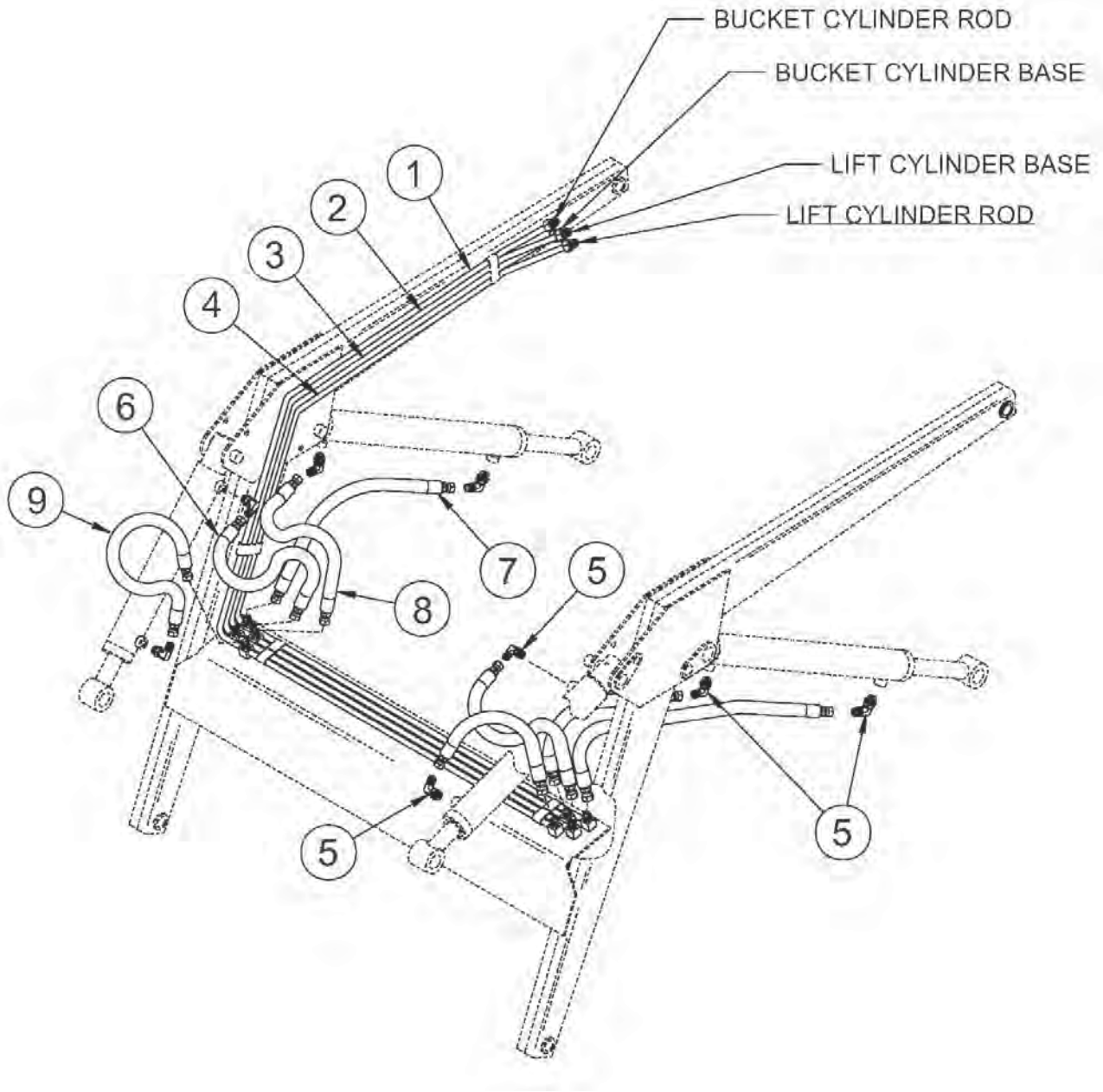

REF. NO.	PART NO.	DESCRIPTION	QTY. REQ'D.
1	46132	Tube, Oil Line (BCR)	1
2	46133	Tube, Oil Line (BCB)	1
3	46130	Tube, Oil Line (LCB)	1
4	46131	Tube, Oil Line (LCR)	1
5	63149100	Fitting, Elbow, 9/16 X 9/16	8
6	32837-1	Hose, .250 X 10.50	2
7	32837-15	Hose, .250 X 34.00	2
8	32837-3	Hose, .250 X 20.00	2
9	32837-7	Hose, .250 X 15.00	2

HYDRAULIC VALVE

Dukes Valve

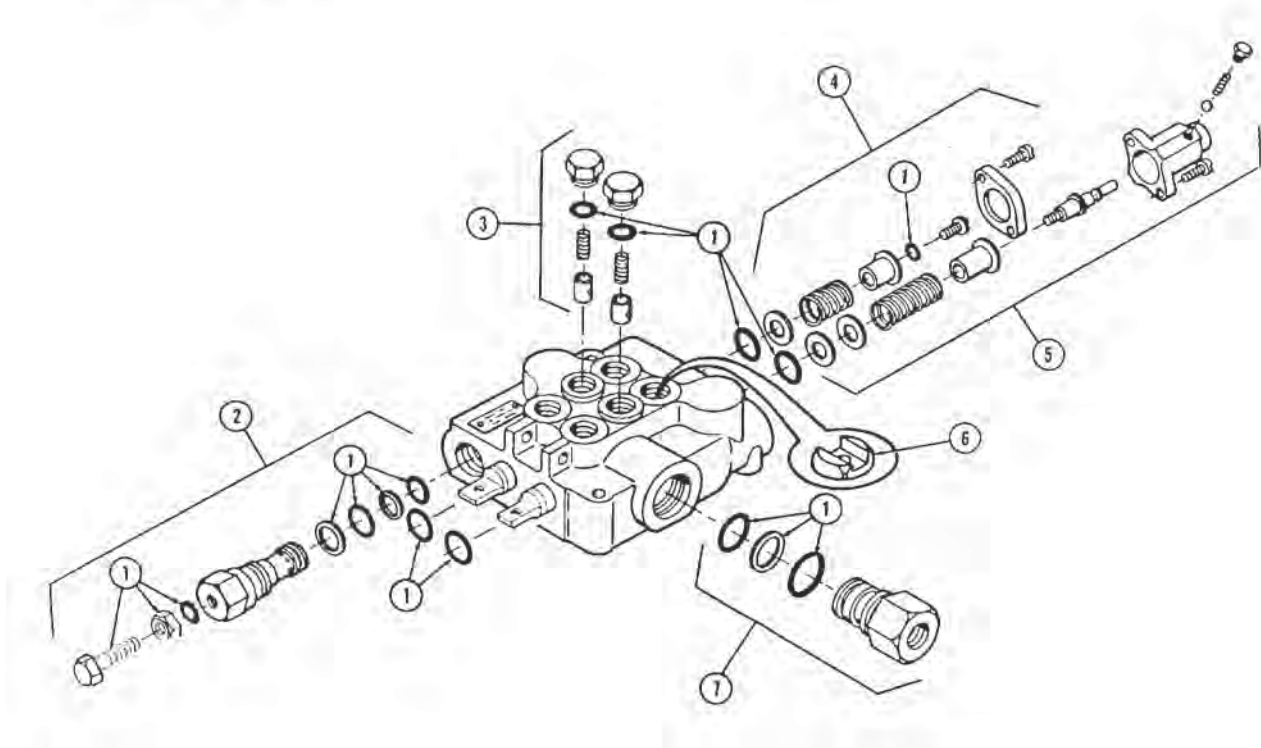

REF. NO.	PART NO.	DESCRIPTION	QTY. REQ'D.
	52190	Control Valve Assy. (Dukes)	1
1	41270+	Repair Kit, Seal - Pilot Operated Relief	1
2	36583	Repair Kit, Pilot Operated Relief	1
3	33101+	Repair Kit, Load Check	2
4	41269+	Repair Kit, Spring Centering	1
5	33103+	Repair Kit, Detent Spring Centering	1
6	25944+	Plate, 1-Way Restrictor W/.109 Hole	1
7	36584	Power Beyond Kit	1

HYDRAULIC CYLINDER - LIFT

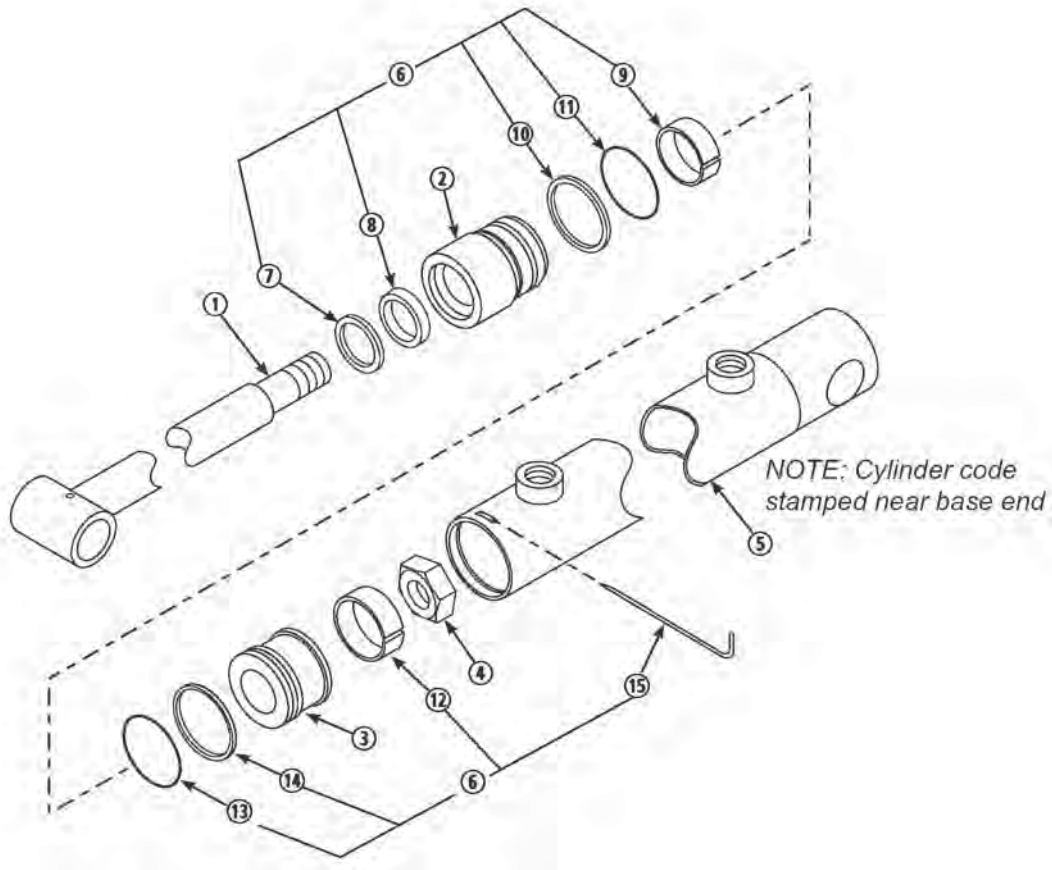

REF. NO.	PART NO.	DESCRIPTION	QTY. REQ'D.
	45302	Cylinder Assy. (Lift)	1
1	45434	Shaft, Cylinder	1
2	45313	Head, Cylinder	1
3	45311	Piston	1
4	-----	Locknut 3/4"-10	1
5	45436	Tube, Cylinder	1
6	45318	Seal Repair Kit	1
7	-----	Seal, Wiper	1
8	-----	Seal, U-Cup	1
9	-----	Wear Ring	1
10	-----	Washer, Backup	1
11	-----	"O" Ring	1
12	-----	Wear Ring	1
13	-----	"O" Ring	1
14	-----	Seal, Piston	1
15	-----	Wire, Retaining	1

HYDRAULIC CYLINDER - BUCKET

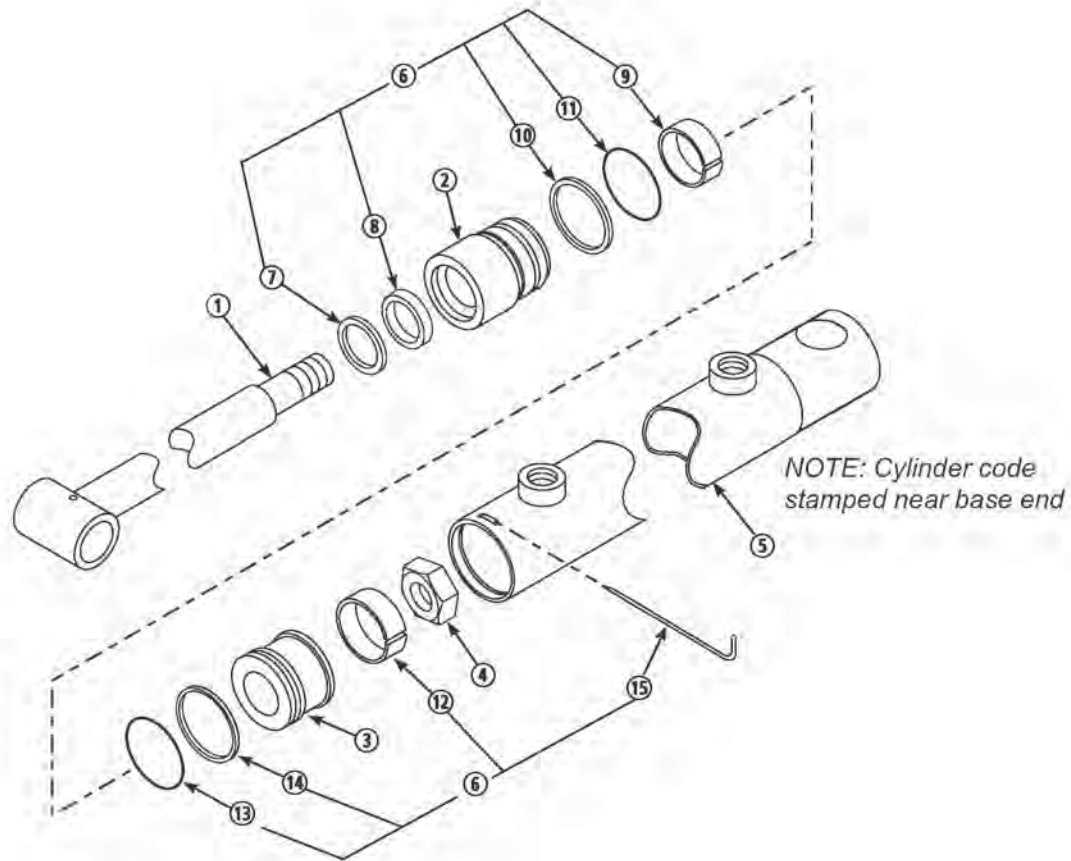

REF. NO.	PART NO.	DESCRIPTION	QTY. REQ'D.
	45303	Bucket Cylinder Assembly	1
1	45430	Shaft, Cylinder	1
2	45313	Head, Cylinder	1
3	45311	Piston	1
4	-----	Locknut 3/4"-10	1
5	45428	Tube, Cylinder	1
6	45318	Seal Repair Kit	1
7	-----	Seal, Wiper	1
8	-----	Seal, U-Cup	1
9	-----	Wear Ring	1
10	-----	Washer, Backup	1
11	-----	"O" Ring	1
12	-----	Wear Ring	1
13	-----	"O" Ring	1
14	-----	Seal, Piston	1
15	-----	Wire, Retaining	1

CONTROL VALVE AND PLUMBING KIT 2-7553

Kubota Models - BX1500, BX1800, BX1830, BX2200, BX2230

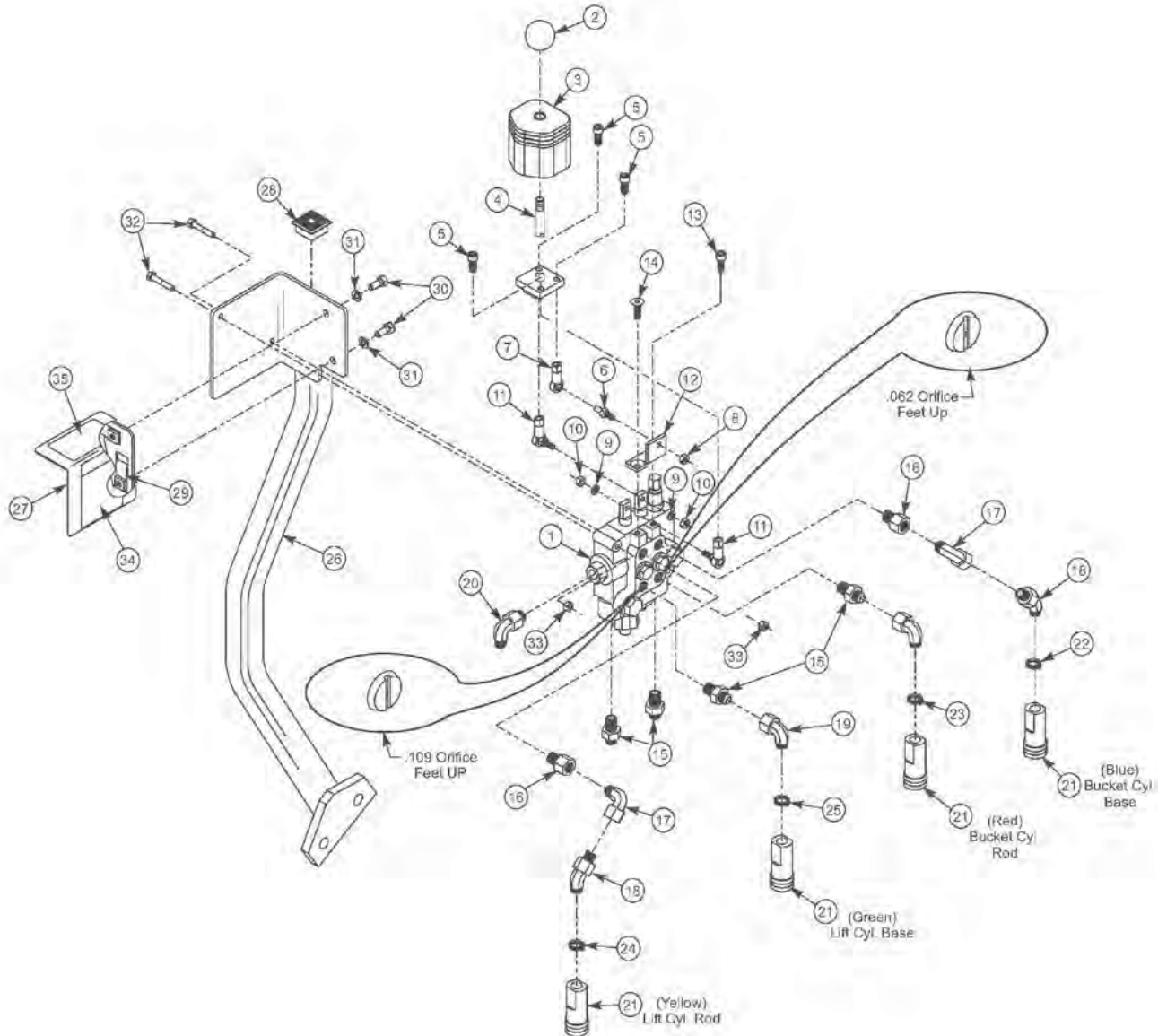

REF. NO.	PART NO.	DESCRIPTION	QTY. REQ'D.	REF. NO.	PART NO.	DESCRIPTION	QTY. REQ'D.
1	51908	Valve, (1600psi)	1	19	44277-2	Fitting, Elbow, 90°, 9/16 Jic X 9/16 O-Ring	2
2	38902	Ball	1	20	32845-1	Fitting, Elbow, 90°, 9/16 Jic X 9/16 O-Ring	1
3	43635	Boot	1	21	6147-9	Coupler, Female	4
4	38902	Handle	1	22	36240-1	Band, Spiral, 3/4", Blue	1
5	-----	Screw, Socket Head, 1/4-28 X 3/4"	3	23	36240-2	Band, Spiral, 3/4", Red	1
6	38904-1	Stud, Ball Joint	1	24	36240-3	Band, Spiral, 3/4", Yellow	1
7	38900-5	Ball Joint, Female	1	25	36240-4	Band, Spiral, 3/4", Green	1
8	-----	Nut, Lock, 1/4-28	1	26	51850	Valve Stand Assembly	1
9	-----	Washer, Lock, 1/4"	2	27	51910	Cover Assembly, W/Decals	1
10	-----	Nut, Hex, 1/4-28	2	28	44274-1	Plug, Square Tube	1
11	26009-3	Ball Joint, Male	2	29	6067-1	Nut, Speed, 5/16-18	2
12	38903	Bracket, Valve Linkage	1	30	-----	Screw, Cap, 5/16-18 X 3/4"	2
13	-----	Screw, Socket Head, 5/16-24 X 3/4"	1	31	-----	Washer, Lock, 5/16	2
14	38911-1	Screw, Flat Head Socket, 5/16-24 X 3/4"	1	32	-----	Screw, Cap, 1/4-20 X 2"	2
15	32844-1	Fitting, Straight, 9/16 Jic X 9/16 O-Ring	4	33	-----	Nut, Lock, 1/4-20	2
16	42062-6	Fitting, Straight, Swivel, 9/16 Jic X 9/16 O-Ring	2	34	25801	Decal, Warning	1
17	34128-3	Fitting, Elbow, 90°, 9/16 Jic X 9/16 Jic	2	35	38929	Decal, Single Handle Control	1
18	31213-5	Fitting, Elbow, 45°, 9/16 Jic X 9/16 O-Ring	2				

CONTROL VALVE AND PLUMBING KIT 2-7553

Kubota Models - BX1500, BX1800, BX1830, BX2200, BX2230

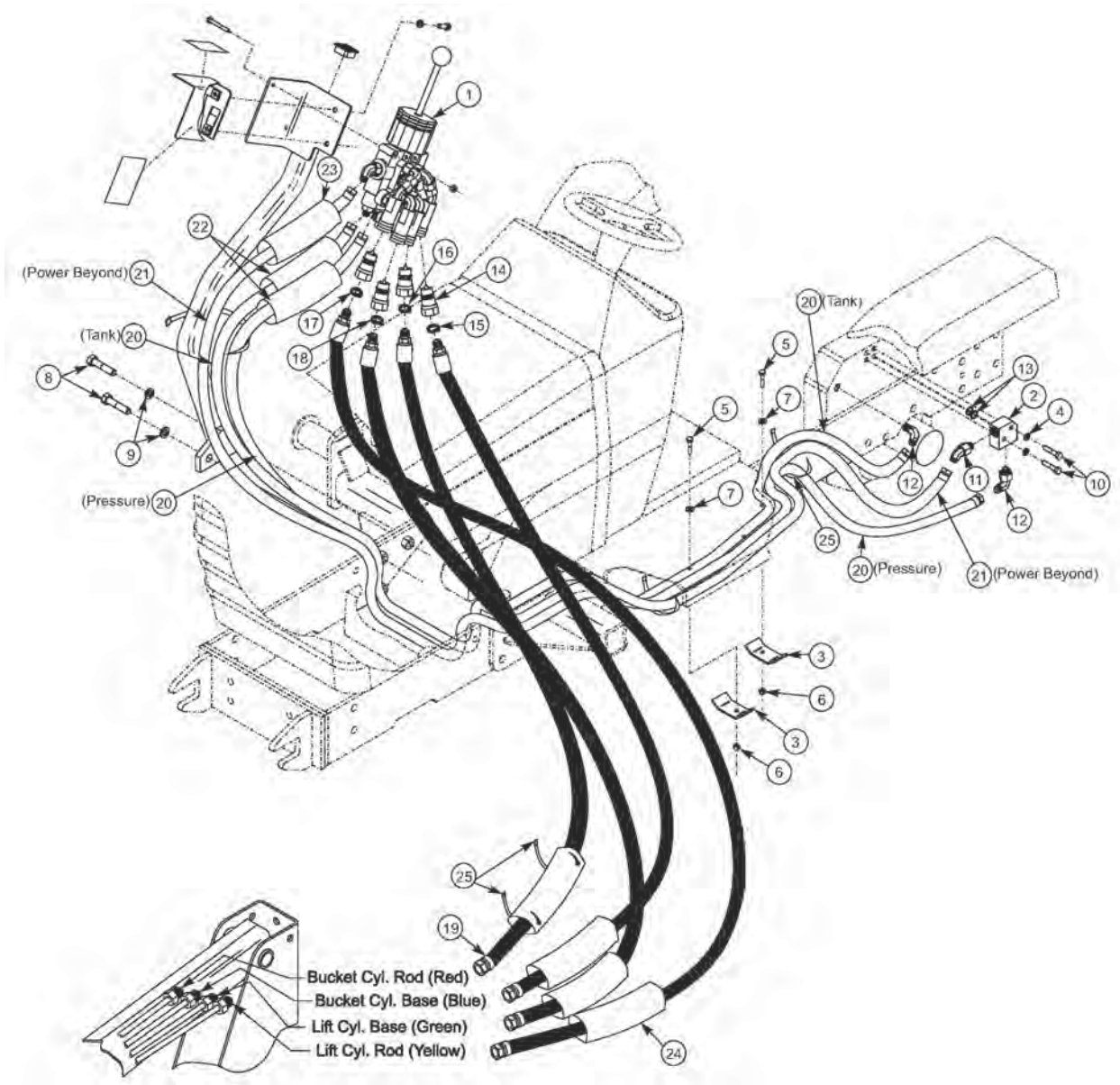

REF. NO.	PART NO.	DESCRIPTION	QTY. REQ'D.	REF. NO.	PART NO.	DESCRIPTION	QTY. REQ'D.
1	51908	Valve, Assembly	1	13	6000-20	O-Ring, 5/8"	2
2	51858	Block, Adapter, Bx1500, Bx1800, Bx2200	1	14	6137-9	Coupler, Male Adapter	4
	53346	Block, Adapter, Bx1830, Bx2230	1	15	36240-1	Band, Spiral, 3/4", Blue	1
3	51857	Clamp, Hose	2	16	36240-2	Band, Spiral, 3/4", Red	1
4	-----	Washer, Lock, 5/16"	2	17	36240-3	Band, Spiral, 3/4", Yellow	1
5	-----	Screw, Cap, 1/4-20 X 1-1/4"	2	18	36240-4	Band, Spiral, 3/4", Green	1
6	-----	Nut, Lock, 1/4-20	2	19	36388-8	Hose, 3/8 X 38"	4
7	-----	Washer, Flat, 1/4"	2	20	36386-10	Hose, 3/8 X 90" (Pressure & Tank)	2
8	-----	Screw, Cap, 9/16-18 X 2-1/4"	2	21	36386-3	Hose, 3/8 X 94" (Power Beyond)	1
9	-----	Washer, Lock, 9/16"	2	22	34853-71	Sleeve, 1.66 X 90"	2
10	-----	Screw, Cap, 8mm-1.25 X 40mm	2	23	34853-72	Sleeve, 1.66 X 94"	1
11	31213-5	Fitting, Elbow, 45°, 9/16 Jic X 9/16 O-Ring	1	24	34853-33	Sleeve, 1.66 X 38"	4
12	2845-1	Fitting, Elbow, 90°, 9/16 Jic X 9/16 O-Ring	2				

CONTROL VALVE AND PLUMBING KIT 2-7408

Massey Ferguson Models - GC2300

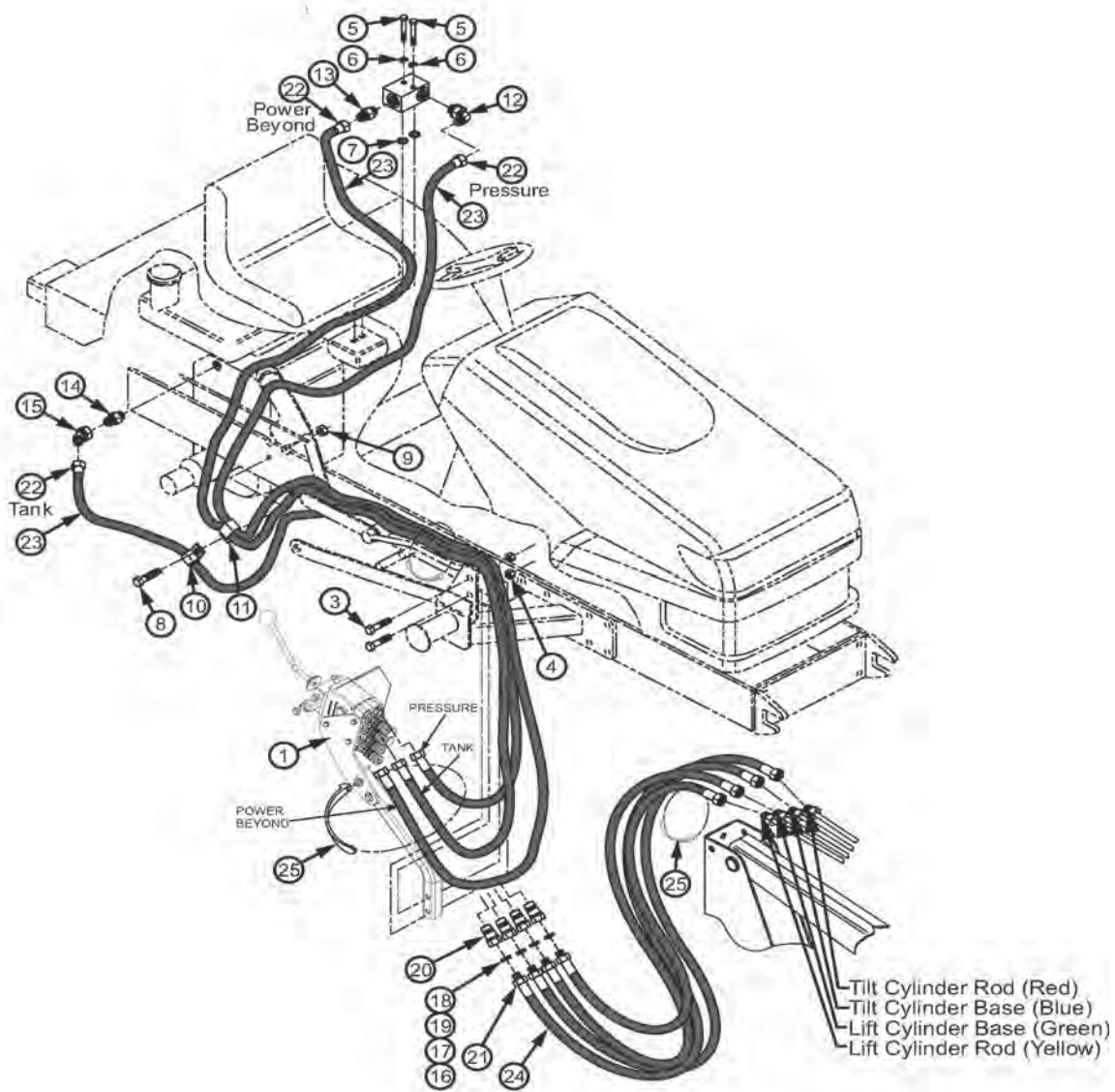

REF. NO.	PART NO.	DESCRIPTION	QTY. REQ'D.	REF. NO.	PART NO.	DESCRIPTION	QTY. REQ'D.
1	53462	Valve Assy.	1	14	36249-1	Fitting - Straight W/ O-Ring	1
2	52183	Adapter Block	1	15	38226-1	Elbow 6 MJIC - 6 FJIC x 45	1
3	-----	Capscrew 1/2-13 x 2.00" Lg Gr5	2	16	36240-5	Spiral Band, Plastic-Blue	1
4	-----	Lock Nut 1/2-13	2	17	36240-6	Spiral Band-Plast-Red	1
5	-----	Capscrew 6mm-1.00 x 45	2	18	36240-7	Spiral Band-Plast-Yellow	1
6	-----	Lockwasher 1/4	2	19	36240-8	Spiral Band-Plast-Green	1
7	6000-20	O-Ring	2	20	6137-9	Coupling, Male 1/4"	4
8	-----	Hhcs 3/8-16 X 1.25" Lg	1	21	36388-8	Hose 3/8 X 38" (Loader Boom Oil Lines)	4
9	-----	Lock Nut Ydp 3/8-16	1	22	32837-18	Hose 0.25 X 72" (Pressure, Tank, And Power Beyond)	3
10	8222-3	Clamp, Tube 5/8 Zp	1	23	34853-78	Nylon Sleeve, 1.00 X 72"	3
11	39047-2	Hose Clamp, Double 0.687	1	24	34853-33	Nylon Sleeve 1 X 38"	4
12	32845-1	Adp Hyd Elbow 6mj - 6mb90	1	25	8137-1	Strap-Adjust .19 X 11.00 B 1	4
13	32844-1	Adapter, 9/16-18 37	1				

CONTROL VALVE AND PLUMBING KIT 2-7408

Massey Ferguson Models - GC2300

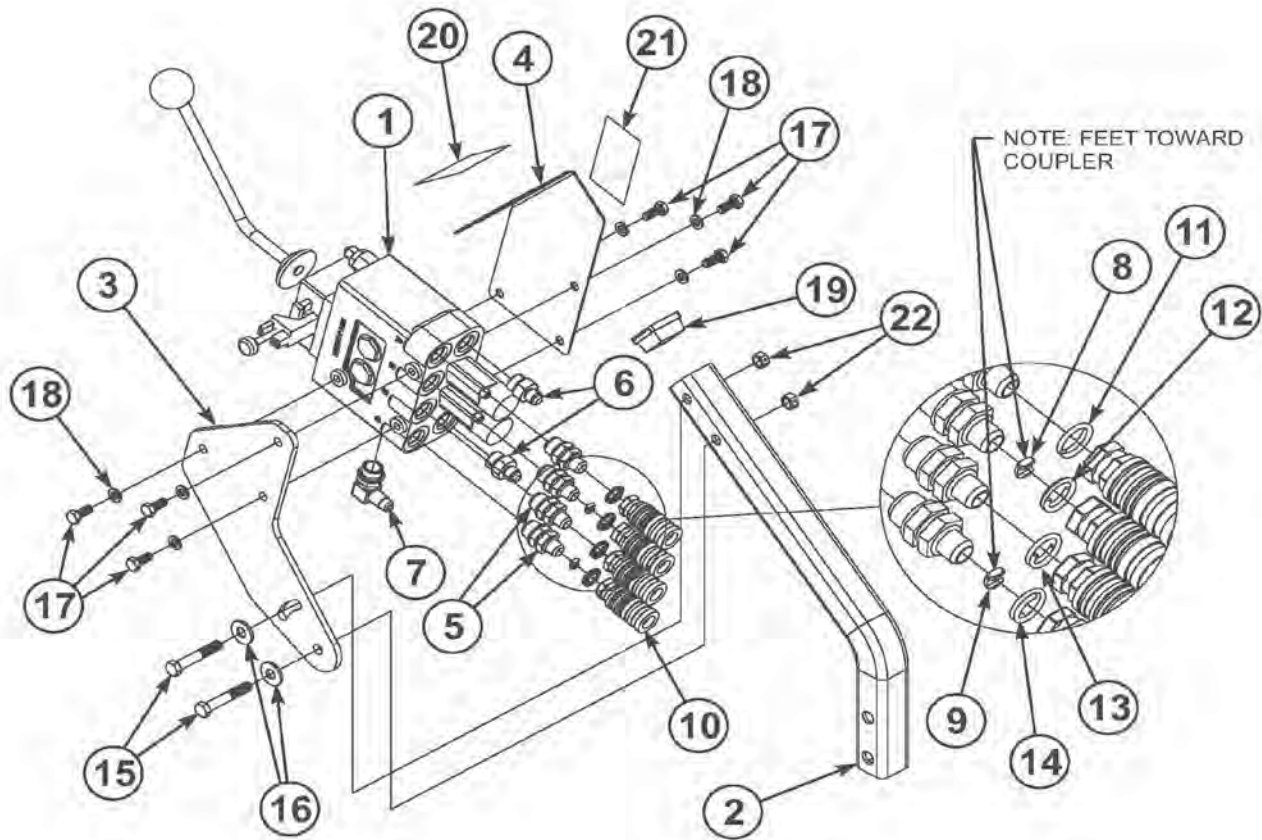

REF. NO.	PART NO.	DESCRIPTION	QTY. REQ'D.	REF. NO.	PART NO.	DESCRIPTION	QTY. REQ'D.
1	53462	Assy, Loader Valve - 1800 Psi	1	12	36240-6	Spiral Band-Plast-Red	1
2	56064	Tube,Valve Mount	1	13	36240-7	Spiral Band-Plast-Yellow	1
3	56065	Plate,Valve Mount	1	14	36240-8	Spiral Band-Plast-Green	1
4	56066	Plate,Valve Cover	1	15	-----	Capscreqw 3/8-16 x2.25" Lg Gr 5	2
5	48670-3	Adapter,Str 8 mab - 6 mb	4	16	-----	Flatwashert 3/8 W-Std	2
6	32844-5	Adaptor, 9/16-18x3/4-16	2	17	-----	Capscrew, 5/16-18 X .75" Lg Gr 5	6
7	32845-7	Adp Hyd Elbow 6mj - 8mb90	1	18	-----	Lockwasher 5/16	6
8	48004	Orifice Plate	1	19	44274-1	Plug, Square Tube	1
9	47879	Orifice Plate	1	20	38929	Decal-Single Handle Control	1
10	6147-9	Coupling Body	4	21	25801	Decal-Warning	1
11	36240-5	Spiral Band,Plastic-Blue	1	22	41840-3	Locknut 3/8-16	2

CONTROL VALVE AND PLUMBING KIT 2-7408

Massey Ferguson Models - GC2300

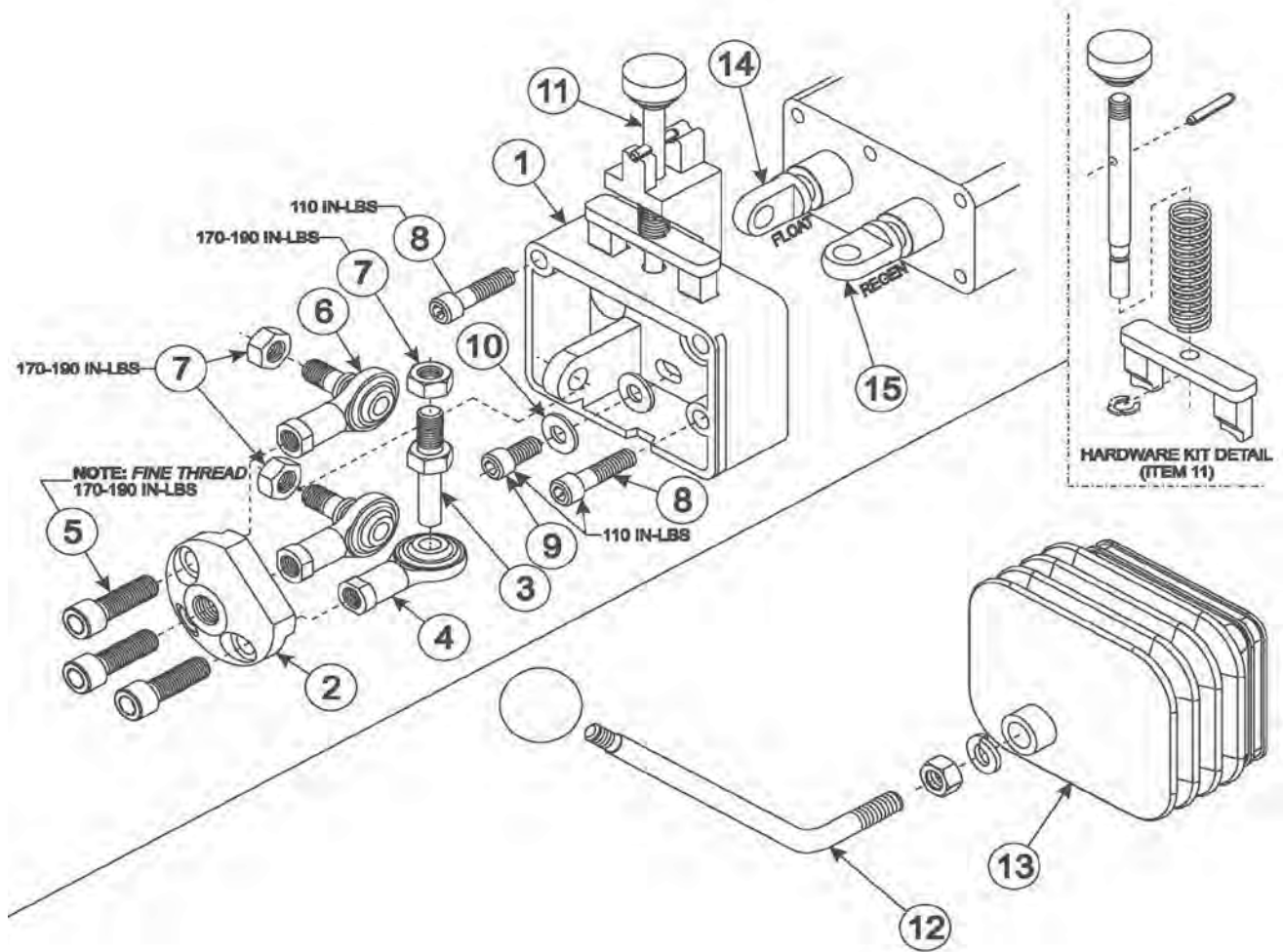

REF. NO.	PART NO.	DESCRIPTION	QTY. REQ'D.
	55827	Kit, Sub-Assy, Includes Items 1-11	1
1	-----	Clevis, Spool Lock	1
2	-----	Plate, Adapter	1
3	55821	Stud, Spool	1
4	55822	End, Rod	1
5	-----	Screw, Cap	3
6	55823	Assy, Rod End	2
7	-----	Nut, Hex	3
8	-----	Screw, Cap	2
9	-----	Screw, Cap	1
10	-----	Washer, Flat	1
11	55824	Kit, Spool Lock Hardware	1
12	56004	Kit, Bent Handle	1
13	55826	Kit, Boot/Cable Tie	1
14	55917	Adapter, Float Spool	1
15	55918	Adapter, Regen Spool	1

CONTROL VALVE AND PLUMBING KIT 2-7443

Case IH Models DX18E, DX22E, DX24E AND DX25EFA
 NEW HOLLAND MODELS - TZ18DA, TZ22DA, TZ24DA, TZ25DA FWA, T1010,
 BOOMER1020 FWA

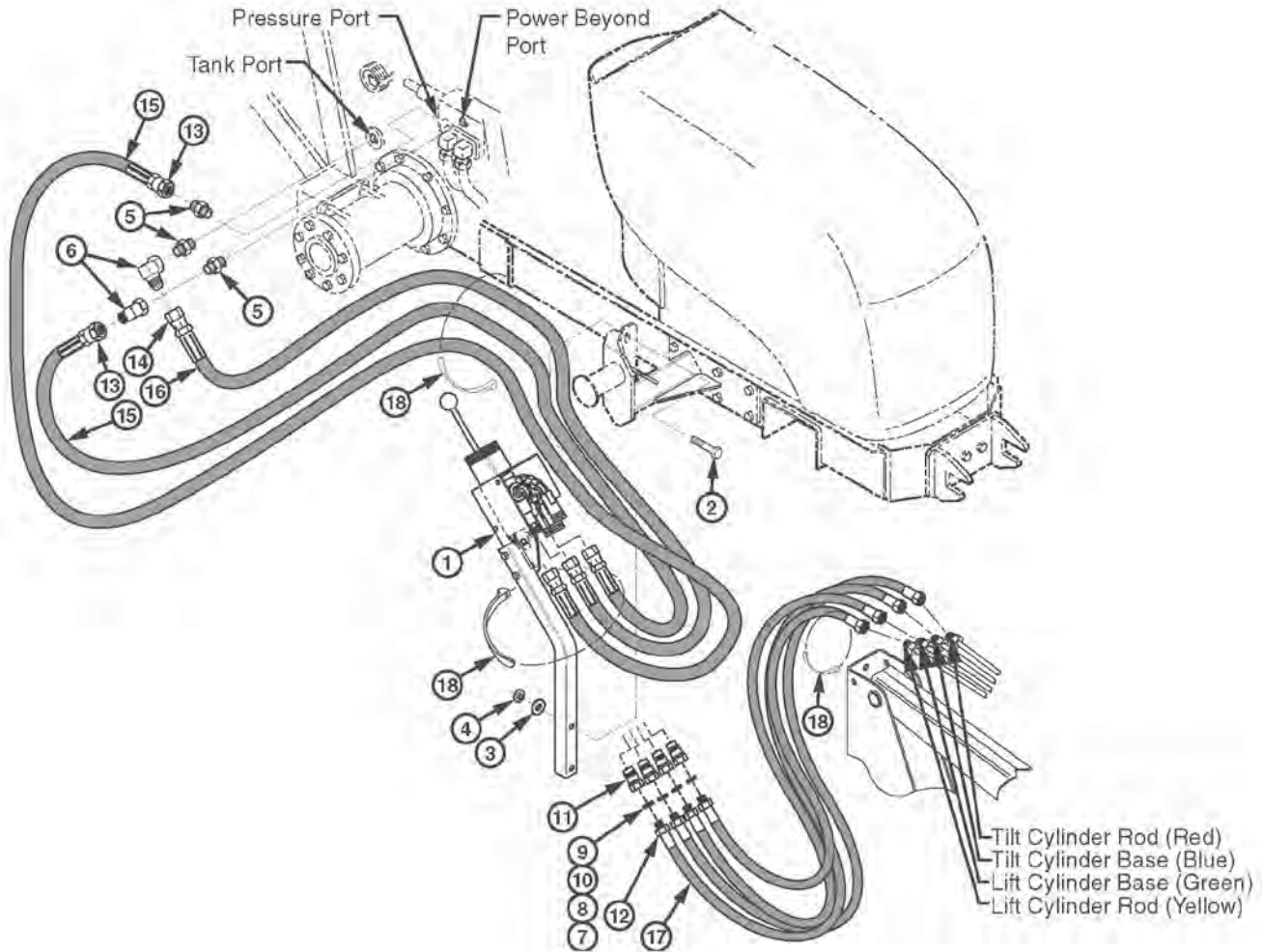

REF. NO.	PART NO.	DESCRIPTION	QTY. REQ'D.	REF. NO.	PART NO.	DESCRIPTION	QTY. REQ'D.
1	52190	Valve, Assembly,	1	10	36240-4	Band, Spiral, 3/4", Green	1
2	-----	Capscrew, 1/2-13 X 2-3/4"	2	11	6137-9	Coupler, Quick, Male	4
3	-----	Flatwasher, 1/2"	2	12	36388-8	Hose, 3/8 X 38" (Loader Boom Oil Lines)	4
4	-----	Locknut, 1/2-13	2	13	36386-18	Hose, 3/8 X 82" (Pressure & Power Beyond)	2
5	43518-2	Fitting, Straight, 1/4 Bspt Male X 9/16 Jic Male	3	14	36386-6	Hose, 3/8 X 72" (Tank)	1
6	34128-3	Fitting, Elbow, 90°, 9/16 Jic F Swivel X 9/16 Jic M	2	15	34853-44	Sleeve, Hose, 82"	2
7	36240-1	Band, Spiral, 3/4", Blue	1	16	34853-78	Sleeve, Hose, 72"	1
8	36240-2	Band, Spiral, 3/4", Red	1	17	34853-33	Sleeve, Hose, 38"	4
9	36240-3	Band, Spiral, 3/4", Yellow	1	18	8137-1	Strap, Adjustable	14
				19	52788	Poppet, Assembly With O-Ring	1

CONTROL VALVE AND PLUMBING KIT 2-7443

Case IH Models DX18E, DX22E, DX24E AND DX25EFA
 NEW HOLLAND MODELS - TZ18DA, TZ22DA, TZ24DA, TZ25DA FWA, T1010,
 BOOMER1020 FWA

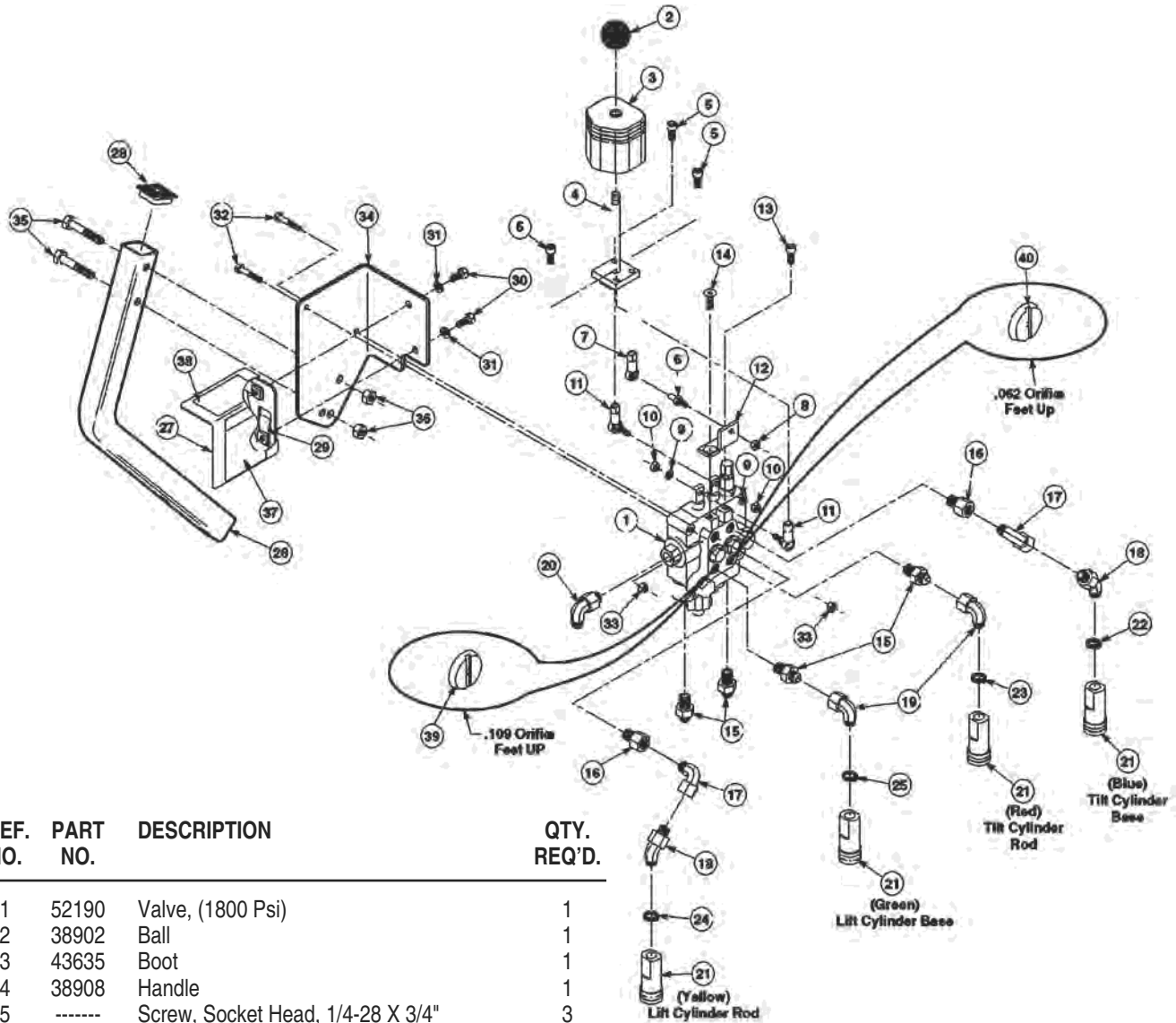

REF. NO.	PART NO.	DESCRIPTION	QTY. REQ'D.
1	52190	Valve, (1800 Psi)	1
2	38902	Ball	1
3	43635	Boot	1
4	38908	Handle	1
5	-----	Screw, Socket Head, 1/4-28 X 3/4"	3
6	38904-1	Stud, Ball Joint	1
7	38900-5	Ball Joint, Female	1
8	-----	Locknut, 1/4-28	1
9	-----	Lockwasher 1/4"	2
10	-----	Hex Nut 1/4 - 28	2
11	26009-3	Ball Joint, Male	2
12	38903	Bracket, Valve Linkage	1
13	-----	Screw, Socket Head, 5/16-24 X 3/4"	1
14	-----	Screw, Flat Head Socket, 5/16-24 X 3/4"	1
15	32844-1	Fitting, Straight, 9/16 Jic X 9/16 O-Ring	4
16	42062-6	Fitting, Straight, Swivel, 9/16 Jic X 9/16 O-Ring	2
17	34128-3	Fitting, Elbow, 90°, 9/16 Jic X 9/16 Jic	2
18	31213-5	Fitting, Elbow, 45°, 9/16 Jic X 9/16 O-Ring	2
19	44277-2	Fitting, Elbow, 90°, 9/16 Jic X 9/16 O-Ring	2
20	32845-1	Fitting, Elbow, 90°, 9/16 Jic X 9/16 O-Ring	1
21	6147-9	Coupler, Female	4
22	36240-1	Band, Spiral, 3/4", Blue	1
23	36240-2	Band, Spiral, 3/4", Red	1
24	36240-3	Band, Spiral, 3/4", Yellow	1

REF. NO.	PART NO.	DESCRIPTION	QTY. REQ'D.
25	36240-4	Band, Spiral, 3/4", Green	1
26	50206	Valve Stand, Tube	1
27	51910	Cover Assembly, Valve, With Decals	1
28	44274-1	Plug, Square Tube	1
29	6067-1	Nut, Speed, 5/16-18	2
30	-----	Capscrew 5/16-18 X 3/4"	2
31	-----	Lockwasher 5/16	2
32	-----	Capscrew 1/4 - 20 X 2"	2
33	-----	Locknut 1/4 - 20	2
34	52529	Angle, Valve Mounting	1
35	-----	Capscrew, 3/8-16 X 2-1/4"	2
36	-----	Locknut, 3/8-16	2
37	25801	Decal, Warning	1
38	38929	Decal, Single Handle Control	1
39	48004	Restrictor Plate .109 Orifice	1
40	25944+	Restrictor Plate .062	1

DECALS

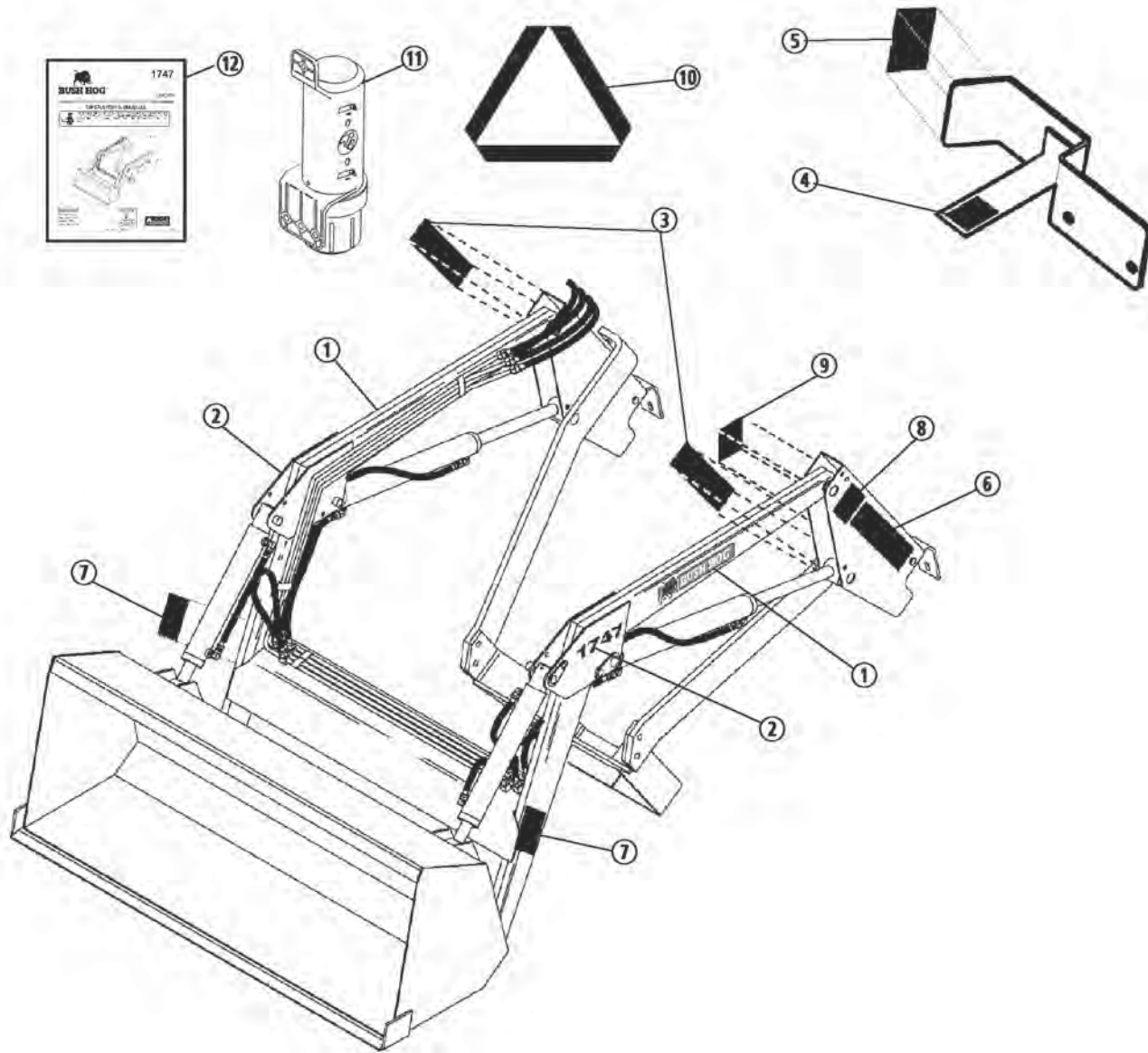

REF. NO.	PART NO.	DESCRIPTION	QTY. REQ'D.
1	50057411	Logo Decal Bush Hog	1
2	50069066	Model 1747	2
3	52740	Warning Oil Leaks	2
4	52203	Warning Lock Valve In Transport	1
5	52204	Instruction Loader Positions	1
6	D469	Warning Loader Safety	1
7	D468	Danger Crushing, Electrocution, Falling Hazard	2
8	D471	Warning Handling Bales	1
9	D470	Danger Use Rops, Seatbelt, Rear Ballast	1
10	03200347	Reflector SMV Sign	1
11	00776031	Canister, Operator's Manual	1
12	50069198	Operators Manual (1747 Loader)	1

DECALS

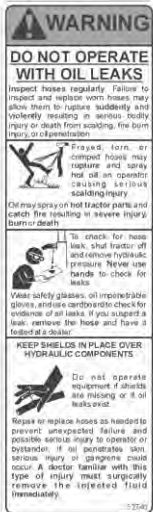
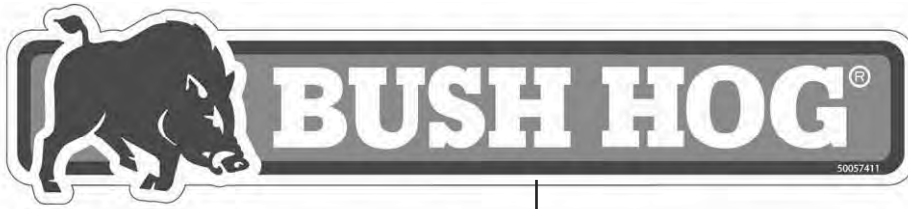

REF. NO.	PART NO.	DESCRIPTION	QTY. REQ'D.
1	50057411	Logo Decal Bush Hog	1
2	50069066	Model 1747	2
3	52740	Warning Oil Leaks	2
4	52203	Warning Lock Valve In Transport	1
5	52204	Instruction Loader Positions	1
6	D469	Warning Loader Safety	1
7	D468	Danger Crushing, Electrocution, Falling Hazard	2
8	D471	Warning Handling Bales	1
9	D470	Danger Use Rops, Seatbelt, Rear Ballast	1



BUSH HOG®

2501 Griffin Ave. • Selma, AL 36703
(334) 872-6261 • (334) 874-2700
Parts Ordering 1-800-304-2836
Fax 1-800-572-1784
www.bushhog.com